

Crimp Terminations (Contacts and Lugs)



For the purposes of this section, the term “terminal” includes both lugs and contacts.

A critical element of any wire termination is the connection between the wire and the terminal. Crimping of terminals is one method of achieving this connection.

The importance of a good termination ensures mechanical integrity and meets electrical requirements for the application.

In addition to the basic requirements outlined in this section, there should also be no damage to plating or finish, no contact deformation that would cause friction or increase force to insert or load the contact into the connector body, and no contact deformation that does not allow all contact locking tabs or wings to fully engage and lock into the connector body. Contact deformation **shall not [D1D2D3]** interfere with form, fit or function of the connector.

Conductor strands **shall not [N1D2D3]** be cut or modified in any manner to reduce circular mil area (CMA) to fit a termination. Contacts **shall not [N1D2D3]** be altered to accept oversized wire or an excessive number of conductors. Conductors **shall not [D1D2D3]** be tinned prior to termination, unless otherwise specified. Solid wire **shall not [D1D2D3]** be crimped except as allowed in 13.2.1.

Terminals, electrical terminations or contacts **shall not [D1D2D3]** be re-crimped or double-crimped (see Appendix A), unless required as part of a documented process for the specific terminal.

Shrinkable sleeving **shall not [N1D2D3]** be applied as insulation diameter buildup unless required by the drawing.

CMA build up is required when the wire gauge CMA is outside the CMA range of the contact. The CMA build up **shall [N1D2D3]** be determined by design engineering and documented in the drawing or by manufacturing engineering and documented in the process. Any material used for CMA buildup **shall [N1D2D3]** be specified on the drawing.

All crimping needs to comply with the terminal manufacturer’s published requirements, e.g., crimp height, pull test, etc., without regard to the specific tooling used. For complete understanding, refer to applicable connector or terminal manufacturer’s requirements and instructions. The quality requirements of the manufacturer of the terminals supersede this document. All crimped terminations need to meet applicable industry requirements, such as EIA, IEC, NEMA, UL or other as designated.

The tooling identified on a terminal manufacturer’s documentation **shall [D1D2D3]** be used.

If alternate tooling is used, there **shall [D1D2D3]** be objective evidence available to show validity of the alternate process.

As an exception, if a terminal is manufactured in accordance with an industry specification, e.g., military, medical, automotive, the tool called out in that specification **shall [N1N2D3]** be used to crimp the terminal.

Crimp tools may be either manually (hand) or automatically operated. All hand tools should employ some form of an integral mechanism to control the crimping operation to the extent that, once the crimping operation has been started, the crimp tool cannot be opened until the crimping cycle has been completed (full-cycle/ratcheting tools). Full-cycle tools **shall [N1N2D3]** be used for Class 3 crimping.

Crimp Terminations (Contacts and Lugs)



For the purposes of this section, the term “terminal” includes both lugs and contacts.

A critical element of any wire termination is the connection between the wire and the terminal. Crimping of terminals is one method of achieving this connection.

The importance of a good termination ensures mechanical integrity and meets electrical requirements for the application.

In addition to the basic requirements outlined in this section, there should also be no damage to plating or finish, no contact deformation that would cause friction or increase force to insert or load the contact into the connector body, and no contact deformation that does not allow all contact locking tabs or wings to fully engage and lock into the connector body. Contact deformation **shall not [D1D2D3]** interfere with form, fit or function of the connector.

Conductor strands **shall not [N1D2D3]** be cut or modified in any manner to reduce circular mil area (CMA) to fit a termination. Contacts **shall not [N1D2D3]** be altered to accept oversized wire or an excessive number of conductors. Conductors **shall not [D1D2D3]** be tinned prior to termination, unless otherwise specified. Solid wire **shall not [D1D2D3]** be crimped except as allowed in 13.2.1.

Terminals, electrical terminations or contacts **shall not [D1D2D3]** be re-crimped or double-crimped (see Appendix A), unless required as part of a documented process for the specific terminal.

Shrinkable sleeving **shall not [N1D2D3]** be applied as insulation diameter buildup unless required by the drawing.

CMA build up is required when the wire gauge CMA is outside the CMA range of the contact. The CMA build up **shall [N1D2D3]** be determined by design engineering and documented in the drawing or by manufacturing engineering and documented in the process. Any material used for CMA buildup **shall [N1D2D3]** be specified on the drawing.

All crimping needs to comply with the terminal manufacturer’s published requirements, e.g., crimp height, pull test, etc., without regard to the specific tooling used. For complete understanding, refer to applicable connector or terminal manufacturer’s requirements and instructions. The quality requirements of the manufacturer of the terminals supersede this document. All crimped terminations need to meet applicable industry requirements, such as EIA, IEC, NEMA, UL or other as designated.

The tooling identified on a terminal manufacturer’s documentation **shall [D1D2D3]** be used.

If alternate tooling is used, there **shall [D1D2D3]** be objective evidence available to show validity of the alternate process.

As an exception, if a terminal is manufactured in accordance with an industry specification, e.g., military, medical, automotive, the tool called out in that specification **shall [N1N2D3]** be used to crimp the terminal.

Crimp tools may be either manually (hand) or automatically operated. All hand tools should employ some form of an integral mechanism to control the crimping operation to the extent that, once the crimping operation has been started, the crimp tool cannot be opened until the crimping cycle has been completed (full-cycle/ratcheting tools). Full-cycle tools **shall [N1N2D3]** be used for Class 3 crimping.

This standard has not established criteria for crimping to wire braid. Crimping to wire braid **shall [D1D2D3]** be as agreed between User and Manufacturer.

Crimp Terminations (Contacts and Lugs) (cont.)

The following topics are addressed in this section:

5.1 Stamped and Formed - Open Barrel

- 5.1.1 Insulation Support Crimp
 - 5.1.1.1 Inspection Window
 - 5.1.1.2 Crimp
- 5.1.2 Insulation Clearance if No Support Crimp
- 5.1.3 Conductor Crimp
- 5.1.4 Crimp Bellmouth
- 5.1.5 Conductor Brush
- 5.1.6 Carrier Cutoff Tab

5.2 Stamped and Formed - Closed Barrel

- 5.2.1 Insulation Clearance
- 5.2.2 Insulation Support Crimp
- 5.2.3 Conductor Crimp and Bellmouth

5.3 Machined Contacts

- 5.3.1 Insulation Clearance
- 5.3.2 Insulation Support Style
- 5.3.3 Conductor
- 5.3.4 Crimping
- 5.3.5 CMA Buildup

5.4 Termination Ferrule Crimp

Crimp Terminations (Contacts and Lugs) (cont.)

The following topics are addressed in this section:

5.1 Stamped and Formed – Open Barrel

- 5.1.1 Insulation Support Crimp
 - 5.1.1.1 Inspection Window
 - 5.1.1.2 Crimp
- 5.1.2 Insulation Clearance if No Support Crimp
- 5.1.3 Conductor Crimp
- 5.1.4 Crimp Bellmouth
- 5.1.5 Conductor Brush
- 5.1.6 Carrier Cutoff Tab
- 5.1.7 Individual Wire Seal Attachment

5.2 Stamped and Formed – Closed Barrel

- 5.2.1 Insulation Clearance
- 5.2.2 Insulation Support Crimp
- 5.2.3 Conductor Crimp and Bellmouth

5.3 Machined Contacts

- 5.3.1 Insulation Clearance
- 5.3.2 Insulation Support Style
- 5.3.3 Conductor
- 5.3.4 Crimping
- 5.3.5 CMA Buildup

5.4 Termination Ferrule Crimp

5.5 Shrink Sleeving – Wire Support – Crimped Terminals

5 Crimp Terminations (Contacts and Lugs)

5.1 Stamped and Formed – Open Barrel

Circular mil area (CMA) **shall not [D1D2D3]** be built up unless specified on design drawings.

There are different configurations for insulation support and ~~crimp areas and for the conductor crimp~~. When designed for a specific terminal ~~configuration~~, insulation support tabs may overlap or bypass.

Figure 5-1 identifies the component parts of a typical stamped and formed open barrel terminal.

When attaching multiple wires to a single terminal, each wire **shall [D1D2D3]** meet the same acceptability criteria as a single wire termination. When attaching single or multiple wires to a terminal the combined CMA of the wires **shall [D1D2D3]** comply with the CMA range for the terminal.

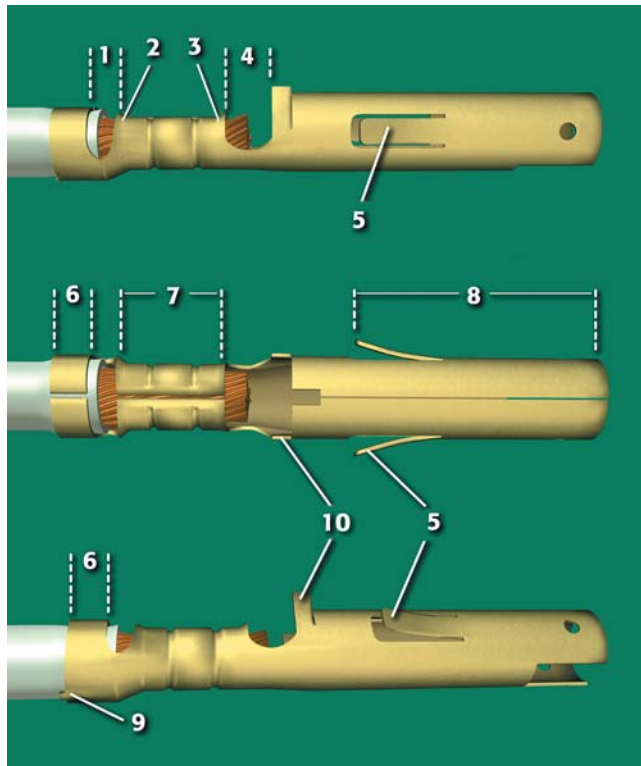

Figure 5-1

1. Insulation inspection window
2. Entry bellmouth
3. Brush end bellmouth
4. Brush inspection window
5. Locking tab/tang
6. Insulation crimp area
7. Conductor crimp area
8. Terminal mating area
9. Cut off tab (may be at either end of terminal)
10. Terminal stop ear

5 Crimp Terminations (Contacts and Lugs)

5.1 Stamped and Formed – Open Barrel

Circular mil area (CMA) **shall not [D1D2D3]** be built up unless specified on design drawings.

There are different configurations for insulation support and conductor **crimps**. When designed for a specific terminal configuration, insulation support tabs may overlap or bypass.

Figure 5-1 identifies the component parts of a typical stamped and formed open barrel terminal.

When attaching multiple wires to a single terminal, each wire **shall [D1D2D3]** meet the same acceptability criteria as a single wire termination. When attaching single or multiple wires to a terminal the combined CMA of the wires **shall [D1D2D3]** comply with the CMA range for the terminal.

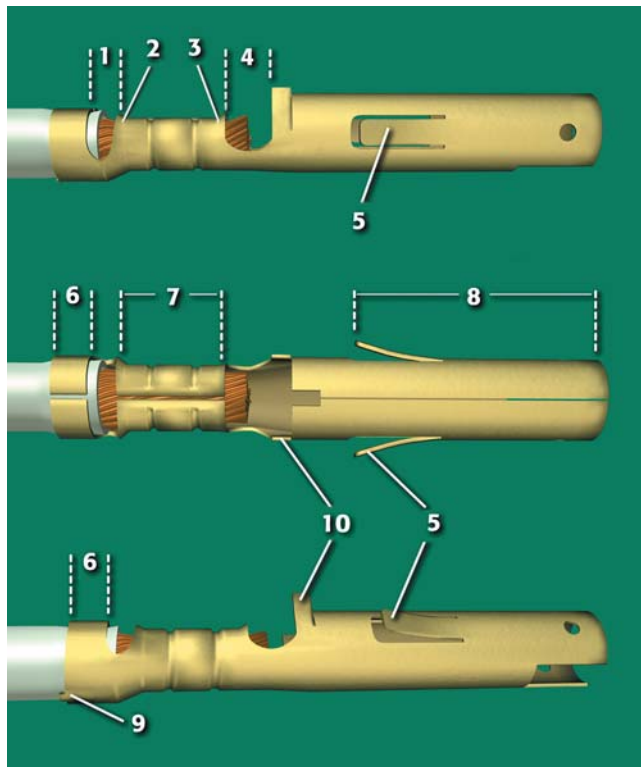

Figure 5-1

1. Insulation inspection window
2. Entry bellmouth
3. Brush end bellmouth
4. Brush inspection window
5. Locking tab/tang
6. Insulation crimp area
7. Conductor crimp area
8. Terminal mating area
9. Cut off tab (may be at either end of terminal)
10. Terminal stop ear